



SYNCHRONOUS MOTOR FAMILY

Series 49mm (A, AB) Geared Synchronous Motor



Output Speed:	.3 to 300 RPM
Torque Range:	Up to 150 oz-in [1059 mN-m]
Insulation Class:	Class A (105°C)
Lead Wire:	4 leads 22AWG (approx. 9 inches [228.6 mm])
Operation Ambient Temp:	-10°C to +40°C (approx.)
Gear Unit:	Zinc Die Cast - AGMA 7 Standard with hardened steel gears
Shaft Bearing:	Sleeve Bearing
 Recognition:	E37163, Component Time Indicating and Recording Appliances, 115Vac 60 Hz Standard Rotor
 Certification:	Card No. 42576, Motors and Generators, 115 Vac, 60 Hz, Standard Rotor, 3 watts max.
Capacitor is required for operation. Capacitor supplied with 115 Vac motors.	
Note: Typical data subject to change without notification	

These motors are among our most popular synchronous motors and are designed for heavy duty usage. The A and AB motors are widely used in computer peripheral equipment, chart drives, medical instruments and a great variety of industrial applications.

Standard motors are 115VAC for 60HZ operation. Other voltages and 50 Hz frequency may be specified. The motors are reversible, and output torque is up to 150 oz-in [1059 mN-m].

Standard and modified involute spur gearing is used in A, P, and T Motor Series. All gears are hobbled to AGMA 7 quality. Pinions are extruded from special steel with a modified long addendum tooth form to provide higher strength. Pinions are held to the same AGMA 7 quality level as the gears. Both pinion and gear teeth are case hardened for wear resistance and rotate upon hardened and ground steel studs.

Output bearings are sintered bronze impregnated with synthetic E.P. oil. Other bearings are grease lubricated and are made from bearing grade phosphor bronze. Lubrication of the gear teeth and studs is provided by synthetic grease with extreme pressure qualities for long life.

Notes:

- Motors Listed below are 115V, 60 Hz models.
- Capacitors are required for operation and must be used in the circuit even if the motor is used in a unidirectional mode.

Model	Part Number	Reduction	Rated Torque (oz-in)	Rated Torque (mN-m)	Output Speed (RPM)	Maximum gear train loading	Input Power (watts)	Voltage (VAC) 50HZ	Voltage (VAC) 60HZ	Capacitor Value (mfd)	Capacitor not supplied	Weight (oz)	Weight (g)	Hi-Torque Rotor
A	3002-023	900	150	1059.2	0.33	X	3		115	0.25		11	312	
A	3002-088	150	150	1059.2	0.33	X	3		24	5.7 100VDC +/-10%	X	11	312	
A	3002-025	600	150	1059.2	0.5	X	3		115	0.25		11	312	
A	3002-001	300	150	1059.2	1	X	3		115	0.25		11	312	
A	3002-059	250	150	1059.2	1	X	2.5	220		0.068 440VAC +/-10%	X	11	312	
A	3002-002	200	138	974.5	1.5		3		115	0.25		11	312	
A	3002-003	150	131	925.1	2		3		115	0.25		11	312	
A	3002-090	125	131	925.1	2		2.5	220		0.068 440VAC +/-10%	X	11	312	
A	3002-005	75	110	776.8	4		3		115	0.25		11	312	
A	3002-035	62.5	92	649.7	4		2.5	115		0.25		11	312	
A	3002-047	75	110	776.8	4		3		24	5.7 100VDC +/-10%	X	11	312	
A	3002-066	62.5	92	649.7	4		2.5	230		0.062 440VAC +/-10%	X	11	312	
A	3002-091	62.5	92	649.7	4		2.5	220		0.068 440VAC +/-10%	X	11	312	
A	3002-007	50	74	522.6	6		3		115	0.25		11	312	
A	3002-074	50	74	522.6	6		3		24	5.7 100VDC +/-10%	X	11	312	
A	3002-078	41.67	61	430.8	6		2.5	230		0.062 440VAC +/-10%	X	11	312	
A	3002-008	37.5	55	388.4	8		3		115	0.25		11	312	
A	3002-009	30	44	310.7	10		3		115	0.25		11	312	
A	3002-049	25	36.5	257.7	10		2.5	220		0.068 440VAC +/-10%	X	11	312	
A	3002-010	25	37	261.3	12		3		115	0.25		11	312	
A	3002-089	20	29	204.8	15		3		24	5.7 100VDC +/-10%	X	11	312	

Model	Part Number	Reduction	Rated Torque (oz-in)	Rated Torque (mN-m)	Output Speed (RPM)	Maximum gear train loading	Input Power (watts)	Voltage (VAC) 50HZ	Voltage (VAC) 60HZ	Capacitor Value (mfd)	Capacitor not supplied	Weight (oz)	Weight (g)	Hi-Torque Rotor
A	3002-013	15	24	169.5	20		3		115	0.25		11	312	
A	3002-015	10	16	113	30		3		115	0.25		11	312	
A	3002-016	5	8.1	57.2	60		3		115	0.25		11	312	
A	3002-020	2.5	4	28.2	120		3		115	0.25		11	312	
AB	3006-002	100	105	741.5	6		5		115	0.5		11	312	
AB	3006-075	83.33	105	741.5	6		4	230		0.12 440VAC +/-5%	X	11	312	
AB	3006-081	83.33	105	741.5	6		4	220		0.15 440VAC +/-10%	X	11	312	
AB	3006-004	60	88	621.4	10		5		115	0.5		11	312	
AB	3006-005	50	73	515.5	12		5		115	0.5		11	312	
AB	3006-042	41.67	73	515.5	12		4	220		0.15 440VAC +/-10%	X	11	312	
AB	3006-007	30	44	310.7	20		5		115	0.5		11	312	
AB	3006-065	30	44	310.7	20		5		24	10 100VDC +/-10%	X	11	312	
AB	3013-007	30	72	508.4	20		6.5		115	0.62		11	312	X
AB	3013-008	25	60	423.7	24		6.5		115	0.62		11	312	
AB	3006-009	20	29	204.8	30		5		115	0.5		11	312	
AB	3006-088	16.67	29	204.8	30		4	230		0.12 440VAC +/-5%	X	11	312	
AB	3013-009	20	48	339	30		6.5		115	0.62		11	312	X
AB	3006-011	15	24	169.5	40		5		115	0.5		11	312	
AB	3006-012	12	19	134.2	50		5		115	0.5		11	312	
AB	3013-012	12	31.5	222.4	50		6.5		115	0.62		11	312	X
AB	3006-013	10	16	113	60		5		115	0.5		11	312	
AB	3006-026	8.5	16	113	60		4	115		0.5		11	312	
AB	3006-014	5	8	56.5	120		5		115	0.5		11	312	
AB	3006-027	4.17	8	56.5	120		4	115		0.5		11	312	
AB	3013-014	5	13	91.8	120		6.5		115	0.62		11	312	X
AB	3006-016	3.5	5.4	38.1	180		5		115	0.5		11	312	
AB	3006-017	3	4.8	33.9	200		5		115	0.5		11	312	
AB	3013-017	3	7.75	54.7	200		6.5		115	0.62		11	312	X
AB	3006-019	2	3.2	22.6	300		5		115	0.5		11	312	

NEW ROUND-SHAPED GEAR MOUNTINGS:

NOTE: ALL Models listed have sleeve bearings.

Model	Part Number	Reduction	Rated Torque (oz-in)	Rated Torque (mN-m)	Output Speed (RPM) 50 Hz	Output Speed (RPM) 60 Hz	Maximum gear train loading	Input Power (watts)	Voltage (VAC) 50HZ	Voltage (VAC) 60HZ	Capacitor Value (mfd)	Capacitor not supplied	Weight (oz)	Weight (g)	Hi-Torque Rotor
A	3002-R01	60	88	621.4	--	5		3	--	24	5.7	X	11	312	
A	3002-R02	60	88	621.4	--	5		3	--	115	.25		11	312	
A	3002-R03	60	72	508.4	4.17	--		3	230	--	.062	X	11	312	
A	3002-R04	30	44	310.7	--	10		3	--	24	5.7	X	11	312	
A	3002-R05	30	44	310.7	--	10		3	--	115	.25		11	312	
A	3002-R06	30	36	254.2	8.33	--		3	230	--	.062	X	11	312	
A	3002-R07	15	24	169.5	--	20		3	--	24	5.7	X	11	312	
A	3002-R08	15	24	169.5	--	20		3	--	115	.25		11	312	
A	3002-R09	15	20	141.2	16.67	--		3	230	--	.062	X	11	312	
A	3002-R10	10	16	113	--	30		3	--	24	5.7	X	11	312	
A	3002-R11	10	16	113	--	30		3	--	115	.25		11	312	
A	3002-R12	10	13	91.8	25	--		3	230	--	.062	X	11	312	

Pear-Shaped Gear:

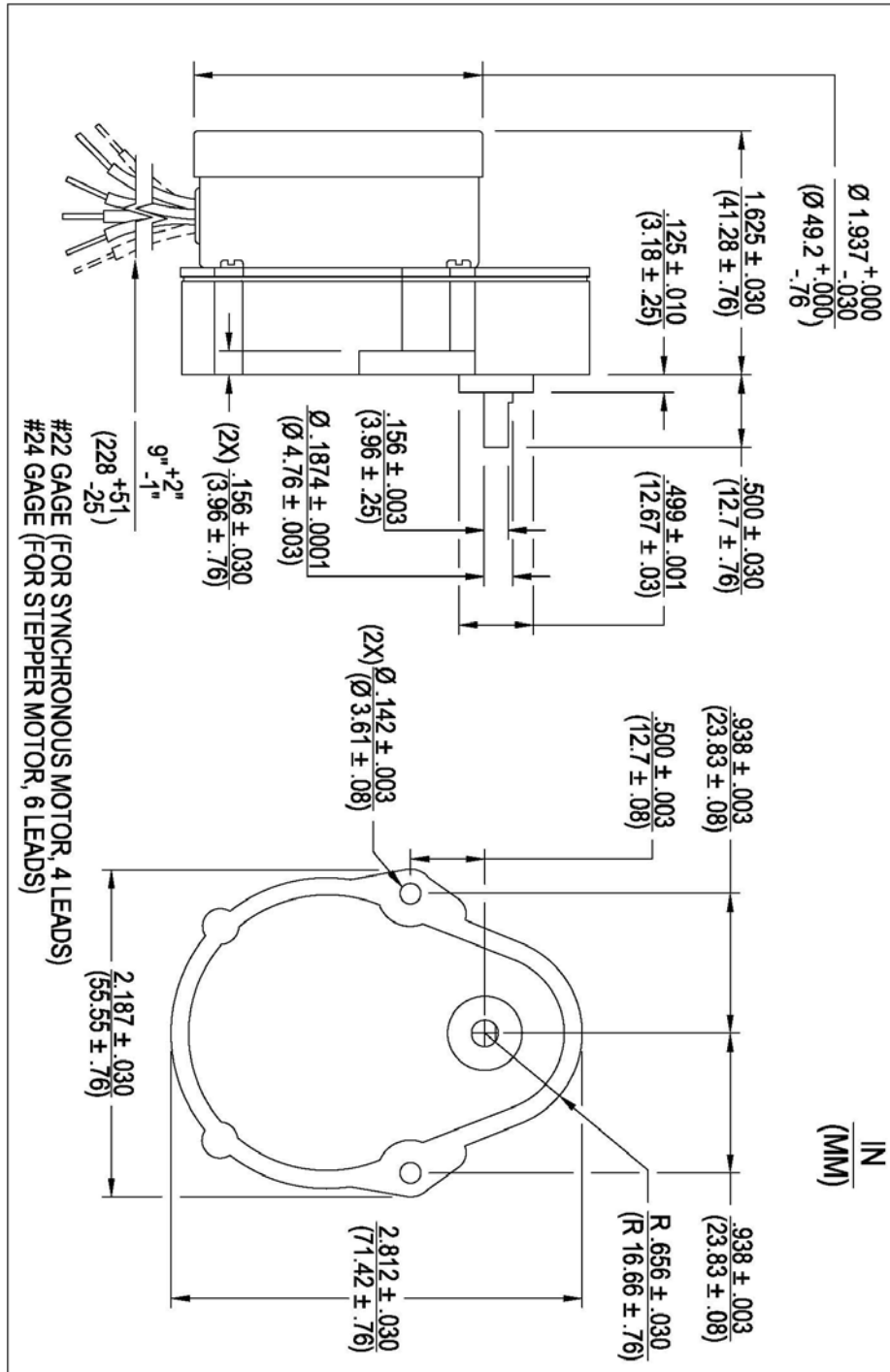

Round-Shaped Gear with Sleeve Bearings:

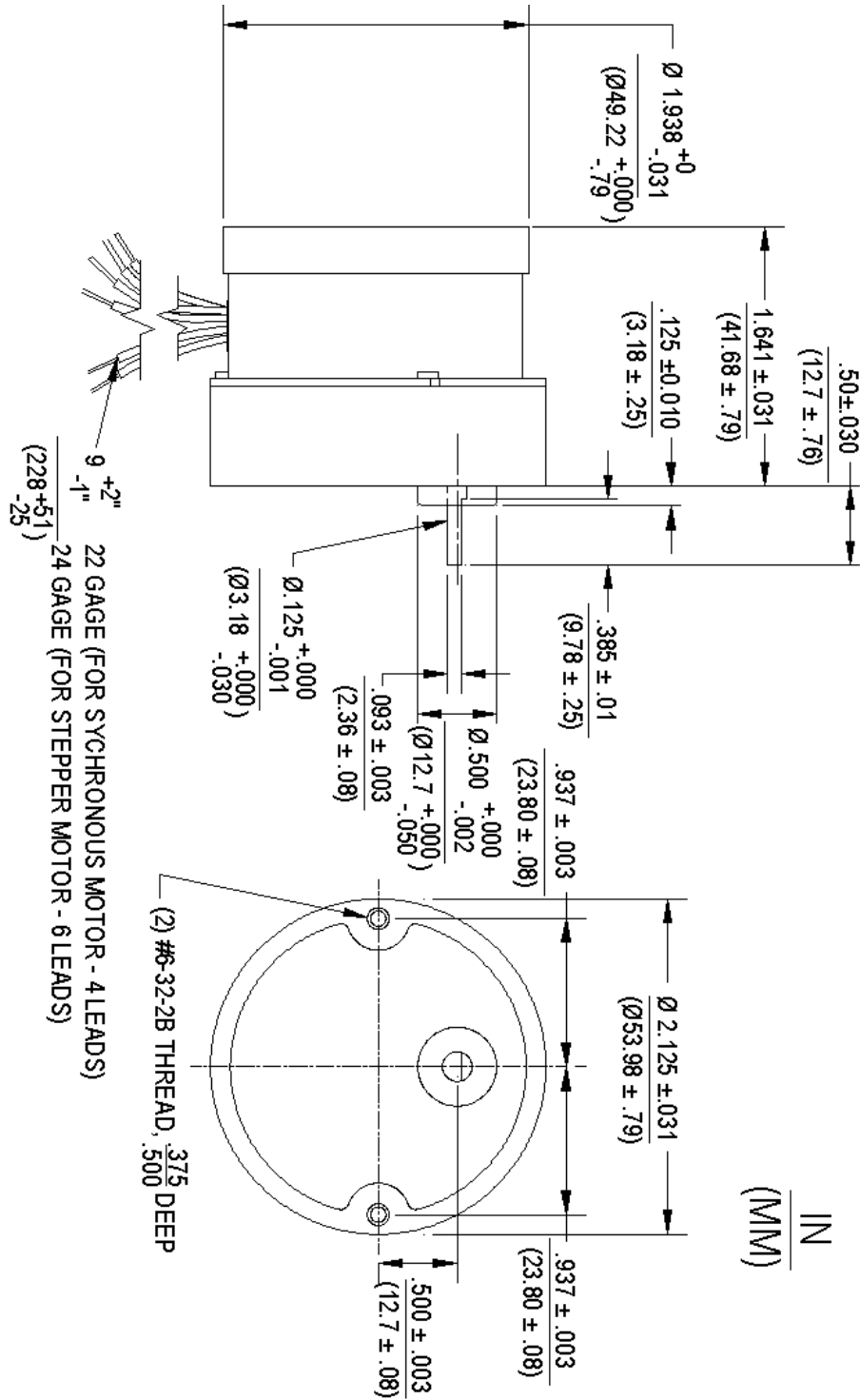

Round-Shaped Gear with Ball Bearings:

Note: (Contact Factory if you desire this construction)

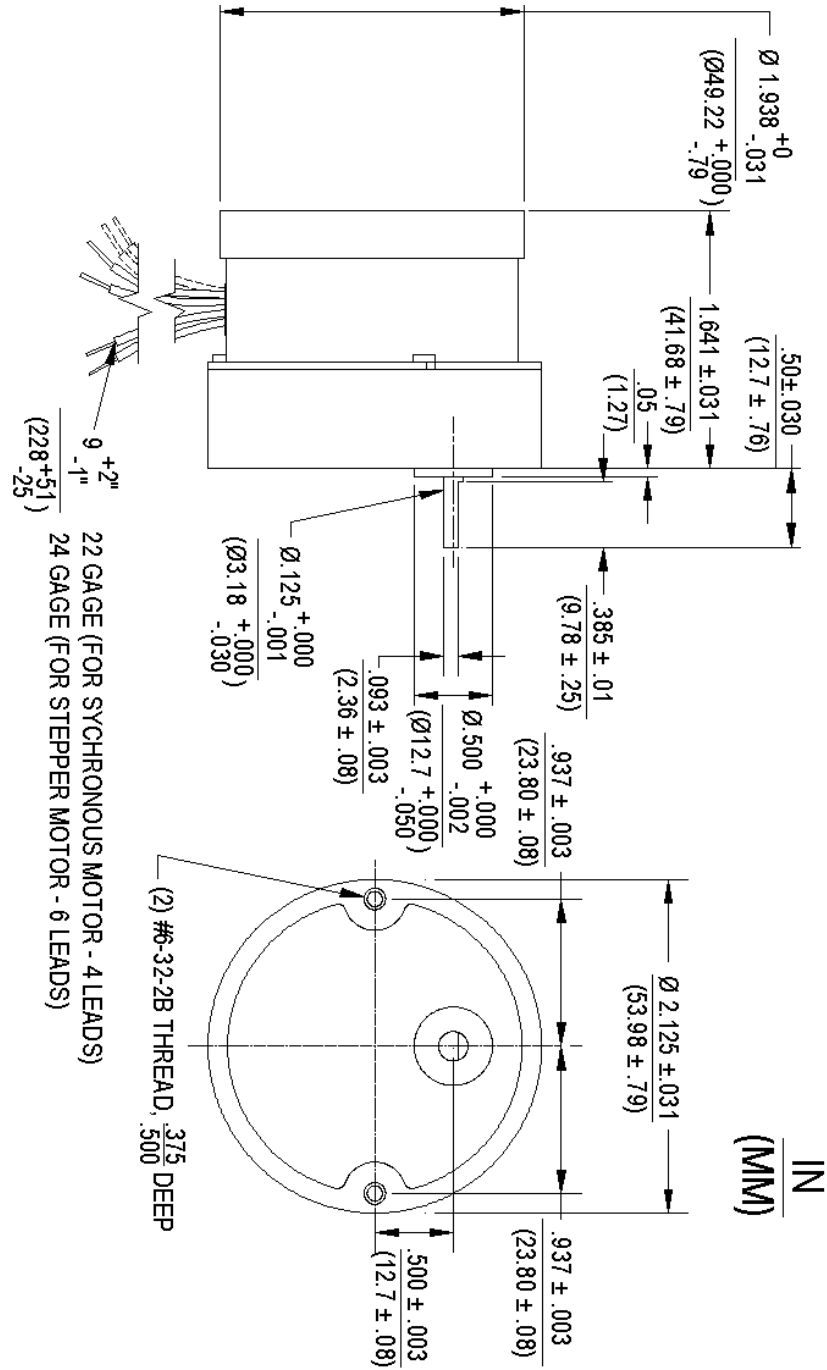

Wiring Diagram

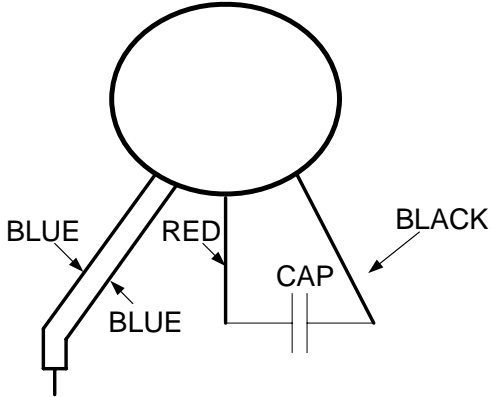

Capacitors are non-polarized and must always be connected between the red and black leads. Always connect the (2) coil blue leads together. Connect the power supply to the blue leads and red lead to produce clockwise (CW) rotation viewing shaft end. Connect the power supply to the blue leads and black lead to produce counter-clockwise (CCW) rotation viewing shaft end.

Optional Wiring Diagram with Switch

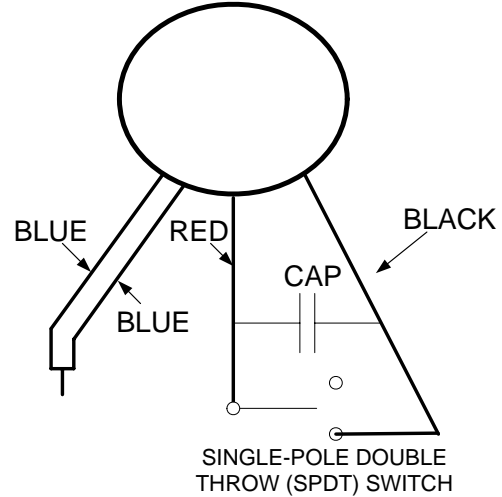

Capacitors are non-polarized and must always be connected between the red and black leads. Always connect the (2) coil blue leads together. Connect the power supply to the blue leads and red lead to produce clockwise (CW) rotation viewing shaft end. Connect the power supply to the blue leads and black lead to produce counter-clockwise (CCW) rotation viewing shaft end.