

STEPPING MOTOR FAMILY

Series 35mm (LSD35) Direct Drive Stepping Motor



Frame Size:	35mm
Step Angle:	7.5°
Steps per Revolution:	48
Position Accuracy:	+/- 5% max.
Number of Phases:	4 phase bifilar
Insulation Class:	Class A (105°C)
Lead Wire:	6 leads 24AWG (approx. 9 inches [228.6 mm])
Operation Ambient Temp:	-10°C to +40°C (approx.)
Temperature Rise:	60 °C Max
Note: Typical data subject to change without notification	

Example: LS G 35 12 E02 P

	Motor Family	Gearing	Motor Size	Voltage	Gear Ratio	Gear Box
Options	LS	D=Direct Drive G=Gearred	35=35MM 42=42MM	005=5VDC 006=6VDC 012=12VDC 024=24VDC	Gear Options	P=Pear-Shaped Gearbox R=Round Gearbox

Model	Part Number	Rated Torque @ 175 p/s (oz-in)	Rated Torque @ 175 p/s (mN-m)	Holding Torque (oz-in)	Holding Torque (mN-m)	Detent Torque (oz-in)	Detent Torque (mN-m)	Output Speed (RPM)	Input Power (watts)	Nominal Voltage (VDC)	Winding Res. (ohms)	Rated Ind. (mh)	Rotor Inertia (oz-in ²)	Rotor Inertia (g-cm ²)	Case Length (in)	Case Length (mm)	Weight (oz)	Weight (g)
LSD35	LSD35005D	2.1	14.8	5.8	41	1.8	12.7	300	3.2	5	16	6.9	0.0372	6.8	0.866	22	2.9	82.2
LSD35	LSD35006D	2.1	14.8	6	42.4	1.8	12.7	300	4.2	6	17.5	9	0.0372	6.8	0.866	22	2.9	82.2
LSD35	LSD35012D	2.1	14.8	6.25	44.1	1.8	12.7	300	4.5	12	65	27	0.0372	6.8	0.866	22	2.9	82.2
LSD35	LSD35024D	2.1	14.8	6	42.4	1.8	12.7	300	4.2	24	280	215	0.0372	6.8	0.866	22	2.9	82.2

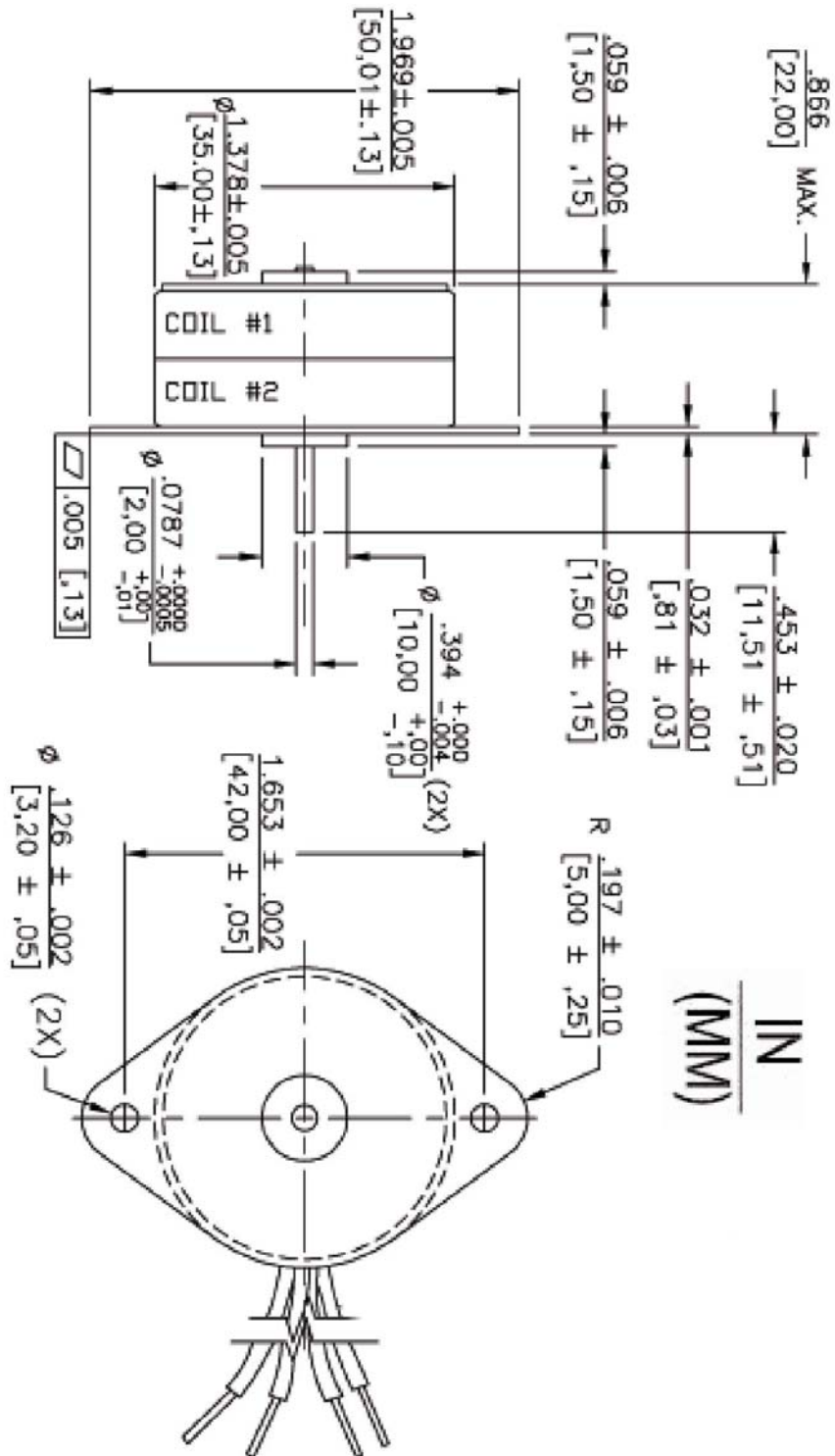

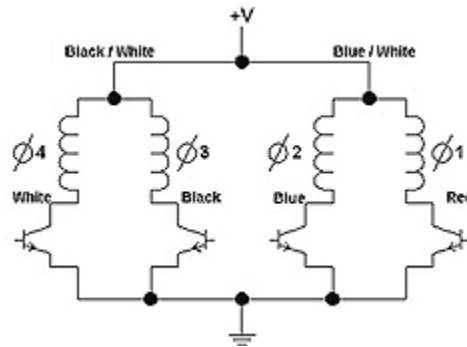
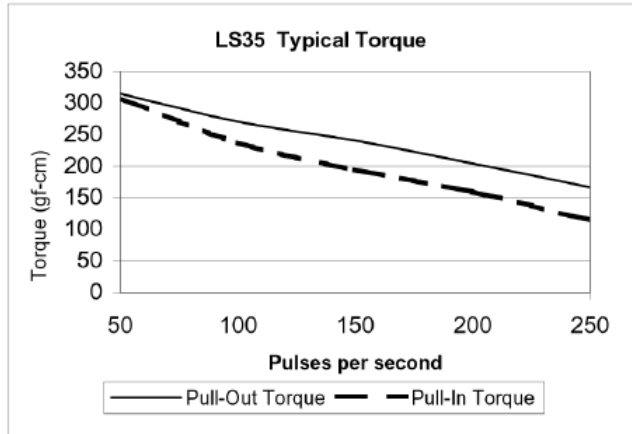
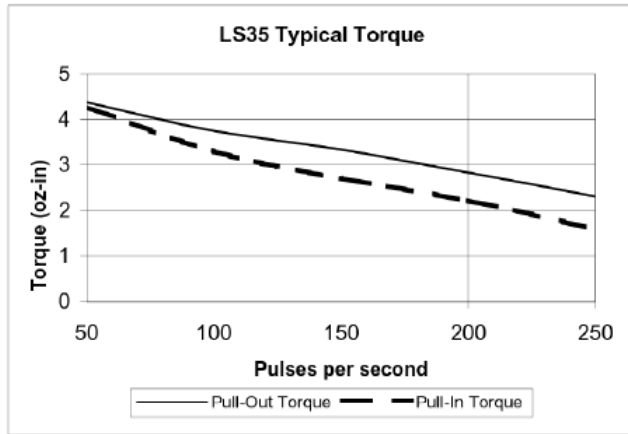

	Ø4 White	Ø3 Black	Ø2 Blue	Ø1 Red	
CCW ROTATION ↑	1	0	1	0	↓ CW ROTATION
	1	0	0	1	
	0	1	0	1	
	0	1	1	0	

1 = ON, 0 = OFF

SWITCHING SEQUENCE